

The Artisan Lab and Pilot Plant ProTherm[®] 50

Rapid concentration of heat sensitive, foaming or toxic materials

The Artisan ProTherm[®] 50 is a horizontal, mechanically-aided, thin film evaporator capable of high vacuum and low or high temperature operation with extremely short residence time. The ProTherm 50 is a specially designed version of Artisan's highly regarded RotoTherm[®] thin film evaporator. This commercially proven solution to tough separations is now available in a size suitable for the laboratory chemist and the pilot plant engineer. It is an excellent closed, continuous alternative to large, glass rotary evaporators with the added benefits of:



- Shorter processing time
- Eliminates bumping and foaming into the condenser
- Easier material handling, especially for toxic compounds
- Reduced risk of product loss (no glass vessels to break)
- Readily scales up to larger commercial operations

The ProTherm 50 has approximately 1/2 square foot of 316L SS electropolished evaporation surface, a 316L SS electropolished rotor, an aseptic mechanical seal, and an explosion proof motor. It is easy to operate, clean, and validate.

How a ProTherm works: Centrifugal force exerted by the rotor blades holds a thin film of feed material against the heated wall. These blades constantly renew the thin film as the incoming feed displaces the progressively more concentrated material towards the bottoms discharge nozzle. High vacuum is maintained in the system to minimize the processing temperature. The residence time is less than one minute.

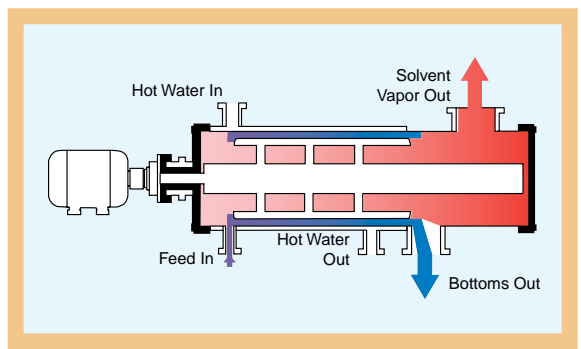

ProTherm 50 Evaporative Capacity

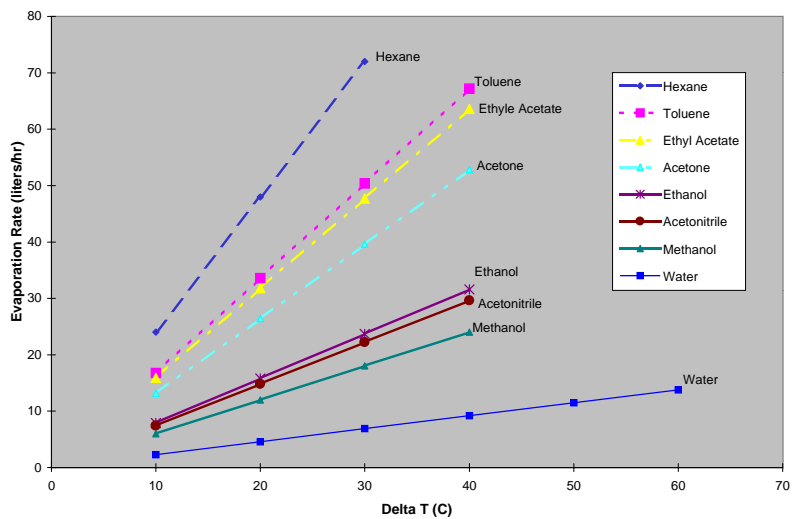

The capacity of the ProTherm 50 depends on the operating conditions and solvent involved.

Evaporation of up to 99% of the solvent can be achieved in a single pass.



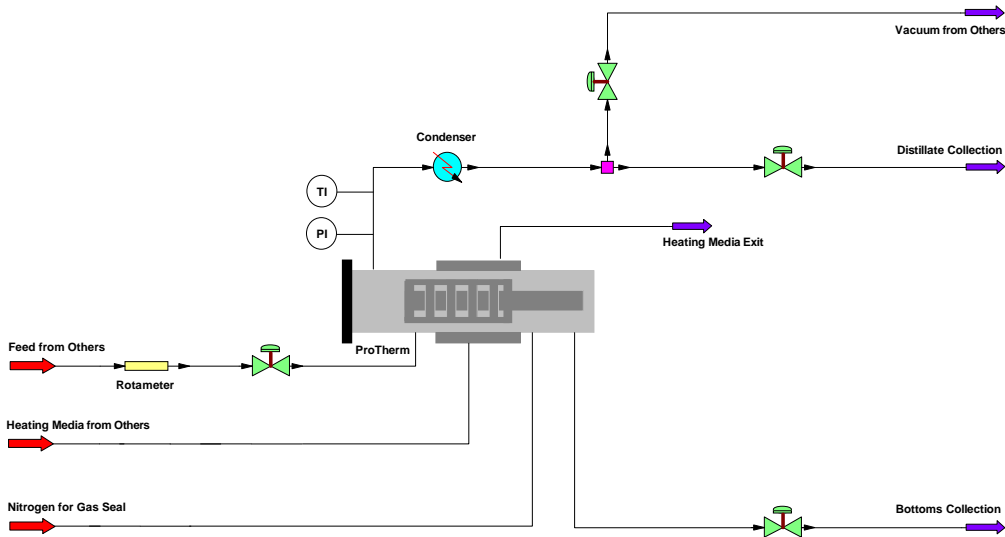

On its user-friendly cart, the Artisan ProTherm 50 can be used in a walk-in hood or moved about the laboratory or pilot plant. The process cart also contains:

- Condenser
- Rotameter / back pressure regulator for feed control
- Quick connects to your laboratory utilities:
 - Vacuum
 - Hot water, glycol, or oil
 - Chilled water for the condenser
 - Nitrogen for the mechanical seal
- Instruments (vacuum and temperatures)
- Electrical: 1 HP, 208-230 VAC, single phase; Class 1, Div. 1, Groups C & D

The cart is offered with either small on board stainless steel product and distillate tanks for batch operation or sanitary fittings for connecting to your lab's existing tanks for extended operation.

Artisan Rototherm evaporators have been widely used in the specialty and fine chemical, pharmaceutical, and food industries for over 40 years. The Rototherm is available in standard and custom sizes up to 200 sq. ft. Materials of construction include stainless steel (300 series and duplex), carbon steel, nickel, Inconel®, Monel®, Hastelloy® and titanium.



5 sq. ft. Artisan Rototherms® used for solvent recovery at a cGMP facility.

- problem definition ❖ technology selection ❖ process design and optimization
 bench scale testing ❖ in house or at site pilot scale testing
 equipment design and specification ❖ complete system manufacture
 start-up assistance ❖ operator training ❖ after sales support

For further information call our sales team at:

781-893-6800

FAX: 781-647-0143 email: chemical@artisanind.com www.artisanind.com
 Printed Dec05 73 Pond Street, Waltham, MA 02451-4594 Bulletin 0101

Since 1934 Artisan experts have led the way, providing integrated solutions to the most challenging separation problems. We combine an innovative approach with an unparalleled depth of knowledge to develop cost effective, practical solutions. Designed and built to exacting standards, our powerful technologies have enabled us to succeed where our competitors have failed. That is why the Artisan name is synonymous with unrivaled product quality and level of service

